

CHURYUMOV G., Doctor of Sciences (Physical and Mathematical), Full Professor (Kharkiv National University of Radio Electronics),
SERKOV O., Doctor of sciences (Engineering), Full Professor (National Technical University «Kharkiv Polytechnic Institute»),
PANCHENKO S., Doctor of Sciences (Engineering), Full Professor (Ukrainian State University of Railway Transport),
TRUBCHANINOVA K., Doctor of sciences (Engineering), Full Professor (Ukrainian State University of Railway Transport).

An antenna for radiating and receiving short-pulse ultra-wideband signals

This paper presents a design of the antenna with an expandable slot for effective radiating and receiving the ultra-wideband (UWB), short-pulse signals. The offered design of the antenna allows creating an interferential electromagnetic field of a bipolar pulse in an equivalent general antenna aperture. A quantitative and quality evaluation of efficiency of proposed antenna design is performed. It is shown that an application of the given antenna allows increasing the propagation range of the pulsed UWB signals.

Ключові слова: data transmission, electromagnetic compatibility, temporal position-pulse modulation, ultra-wideband signal, wideband pulsed antenna, wireless system.

Introduction

One of the main tendency in the development of modern communication and radar technologies is the use of broadband and ultra-wideband (UWB) signals. As defined in [1], the UWB signals have an absolute bandwidth (at least 500 MHz) is calculated as the difference between the upper frequency f_H of the -10 dB emission point and the lower frequency f_L of the -10 dB emission point, $B = (f_H - f_L)$, comparable to its center frequency $f_C = (f_H + f_L) / 2$ so that the fractional (relative) bandwidth $B_f = B / f_C$ larger than 0.2.

One of the varieties of the UWB signals is the short-pulse (SP) signals. It is generally believed that these signals have a duration of about 0.1...10 ns. They have a wide bandwidth, significant penetration and stealth. Their use allows to obtain high data transfer rates and is very promising for future development of recent ultra-wideband systems (UWS). On the other hand, the practical application of the SP-UWB signals causes some difficulties associated with their radiation (or the choice of

antenna type) and subsequent distortions caused by uneven attenuation of the signal in frequency during its propagation.

Thus, the effectiveness of using the SP-UWB signals depends directly on the characteristics of the antennas that produce their radiating and receiving. Among basis requirements which are subject to these antennas can indicate the following:

- ensuring minimal distortion of UWB signals and ultrashort video pulses;
- ensuring a sufficiently high level of signal transmitted to the receiving device;
- high spatial resolution capabilities for signals;
- reasonable overall dimensions and weight of the antenna.

At the present time, the quantities of these requirements are far to be fully resolved and require carrying out the additional research.

This paper considers design of antenna and the feature of receiving and emitting the UWB-SP signals for effective solution of existing problems in communications and radar technologies.

Problem and its Analysis

Nowadays one of the requirements in the development of communications technologies is improving the bandwidth of the radio electronic systems. To achieve this purpose became possible due to applying UWB-SP signals, in particular, of ultrashort pulses with the duration of the order of units of a nanosecond (see, for example, [2]). The basis of technical solutions is the transmission of low-power coded pulses in a

very broad band without carrier frequency. In this case we deal with a nonharmonic oscillation, and consider generation of an ultrashort monopulse, whose duration can fluctuate within 0.2 - 2 nanoseconds, with the period of pulse sequence being from 10 to 1000 nanoseconds. The average period of repeating monopulses defines an information rate. Thus, within a pulse repetition cycle of 10 nanoseconds the maximum transmission rate will be 100 Mbps. The information is coded by means of temporal position-pulse modulation while the pulse shifting in the sequence concerning its regular placement sets "0" forward and "1" backward. Moreover, the time of shifting does not exceed a quarter of monopulse duration, and one information bit is coded by the sequence of multiple monopulses, for example, of 200 impulses per an information bit. So, in the sequence of 0.5 nanosecond pulses with an pulse separation of 100 nanoseconds the pulse which arrives 100 nanoseconds earlier is "0", and 100 nanoseconds later is "1". Simultaneously, in order to divide transmission channels, the position of each impulse is shifted for the period of time, proportional to the current value of some pseudorandom sequence carrying out an additional coding. The division is accomplished by means of temporal bounces, and the time of shift is one or two orders higher than the shifting within temporal position-pulse modulation. Thus, separate communication channels are formed and protected from interfering signals. As a result, the signal range significantly smoothens and becomes noise-type.

Major perspectives in the application of UWB-SP signals are caused by a number of advantages, among the most essential ones is the lack of interference of a directly expanding signal with its reflections from different objects. Besides, attenuation of a short-pulse signal in different environments is not enough due to wideband. They easily penetrate various obstacles, as the signal is not suppressed within the whole range. At the low level of the transmitted signal, the emission security, the degree of information security and the reliability of channels in wireless communication systems are increased.

Antennas for communications

A feature of designing radio electronic systems while applying UWB-SP signals is specified by the processes of changing signal parameters at their passing via the transmitting and receiving antennas. As the antenna

aperture size is much bigger than the ping length of a signal in space, there occurs a delay of signal emission from different elementary sections of the antenna. A current pulse, propagating along an emitter, consistently excites its elements by short monopulse signals. Emissions of separate antenna sections produce a total field [3], which is defined by the following ratio:

$$E_z(t, \theta) = \frac{Z_0 \sin \theta}{4\pi r} \cdot \frac{1}{\cos \theta - 1} \times \left[i \left(t - \frac{L}{c} - \frac{r - L \cos \theta}{c} \right) - i \left(t - \frac{r}{c} \right) \right], \quad (1)$$

where $E_z(t, \theta)$ – intensity of an electric z-component of the electromagnetic field;

Z_0 – wave resistance of free space;

θ – angle between the axis of the emitter and the direction to the observation point;

r – distance to the observation point;

L – antenna aperture size;

c – velocity of light.

The analysis of the ratio (1) points that the field of the antenna consists of two parts, positive and negative. Each of the constituents repeats an exciting current form, with one part of this field being formed at the moment of inputting a current impulse in an emitter, and the other one – at the moment of achieving the end of an emitter by this impulse. Thus, the total field consists of separate fields emitted from an excitation point and the ends of the antenna. Moreover, the form of a total field depends on a ratio between the length of the antenna L and pulse duration ct . At $L \gg ct$ the signal delay time in antenna elements considerably exceeds the pulse duration. As a result, between two parts of the field emitted there is an interval formed, and the field is divided into two parts corresponding to two components. What is more, the form of the emitted field changes depending on the angle of observation θ . The natural experiment [3] confirmed the results of modeling. In the classical theory of antennas according to the principle of reciprocity, the form of the antenna pattern remains invariable under the emission and reception of narrowband signals. This principle is violated, when short ultra-wideband monopulse signals are used. Antenna patterns significantly differ in the mode of emission and reception that is the peculiar feature of applying radio systems using UWB-SP signals.

It is necessary to note, that the UWB-SP signals normally possess the form of idealized Gaussian monocycles whose main part of an emission spectrum is in the range of frequencies from 1 to 7 GHz. In addition, forming the emission of an electromagnetic wave of the UWB signal into free space imposes restrictions on the

constructions of the antenna arrangements applied. The analysis of antenna constructions for emitting ultrashort pulses showed that by means of fractals it is possible to create a broadband antenna while considerably reducing the construction size [4,5]. A fractal may be found by dividing a figure into more and more minute objects, with any of the found figures being divided into identical ones and, in turn, being a part of the similar figure. The corresponding class of antennas is referred as a space-filling antenna (SFA). They are accomplished on the basis of the Koch's, Minkowsky's, Serpinskiy's fractals [5,6].

These elements of fractal antennas have sufficient broadbandness and small sizes. However, the most acceptable emission of the UWB signals is an antenna element representing an antenna with an expandable slot or so-called tapered slot antenna (TSA) with exponentially tapered profile, also known as Vivaldi's antenna [7, 8].

The Vivaldi's antenna is a well-known and widely used antenna in different ultra-wideband systems. The synthesis of such antennas is represented in a lot of

scientific works. For manufacturing the Vivaldi's antenna, we used the photoprinting methods on a dielectric substrate coated with a thin layer of copper. The mathematic antenna model was created in the CST software environment. The simulation results of the basic its characteristics shown in Figs. 1, 2 and 3

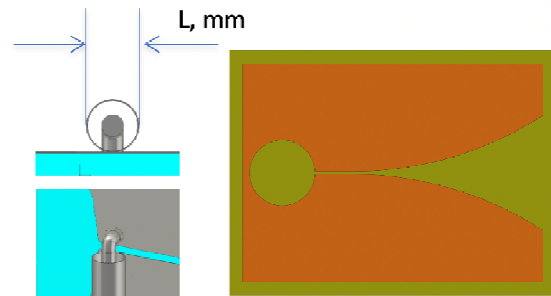

Fig.1. Antenna's geometry

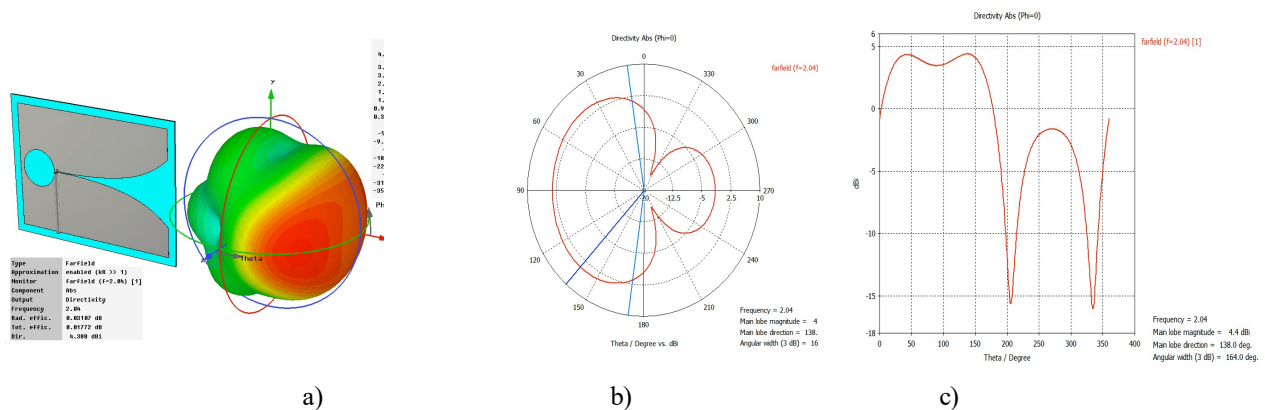

Fig.2. 3-D (a) and 2-D (b and c) directional pattern of the antenna at the 2040 MHz

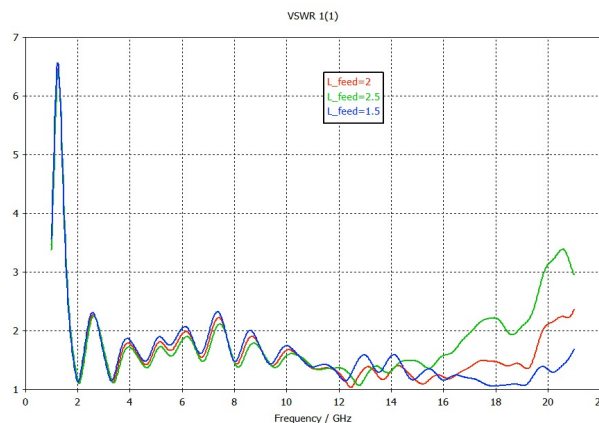

Fig.3. Dependence of the modulus of the reflection coefficient vs frequency for different ports

As it is seen, the shape of the open slot determines the frequency band, with the exponential increasing the width of the slot gives the widest band. The directional energy diagram of such antenna is characterized by a narrow main beam and practically the lack of side lobes. Structurally, the TSA is usually produced in the form of printed conductors on glass fiber laminate. The antenna has an irregular surface shape, therefore, in order to investigate the characteristics of such an antenna there is a software package used for three dimensional electrodynamic modeling. The optimization of the TSA sizes and forms gives a variety of forms and proportions, depending on solving a specific objective, however it is essential expansion of a frequency band of electromagnetic radiation that is defining while applying UWB electronic systems. Thus, the urgent task is to improve technical characteristics of the TSA elements of the antenna systems, which emit ultrashort pulses and don't distort a waveform and reduce the side antenna radiation.

To achieve the aim is obtained by using a bipolar pulse signal in the construction of an antenna element, which is schematically presented in Fig. 5 [9]. The

information monopulse signal is divided into halves for this purpose. One part of the signal is consistently inverted and delayed for some period of time that is equal to the half of monopulse duration. Both monopulse signals are used to excite respectively two of the TSA antennas located nearby on a unified dielectric basis. The electromagnetic fields of both monopulse signals are interfered in equivalent generic space of an aperture of both antennas, producing in it an electromagnetic field of a bipolar impulse, simultaneously eliminating the time slot between two parts of an emitted field that is characteristic of the TSA antenna. This bipolar impulse makes the emission whose range considerably exceeds the maximum distance when using both monopulse and harmonious signals.

The Fig. 4 schematically presents the construction of a broadband pulse antenna. It is indicated as follows: 1 – generator of a broadband unipolar pulse signal; 2 – dielectric basis; 3-1, 3-2 – the conducting surfaces; 4-1, 4-2 – excitation systems; 5-1, 5-2 – emitting apertures; 6 – signal divider combined with the inverter; 7 – delay line.

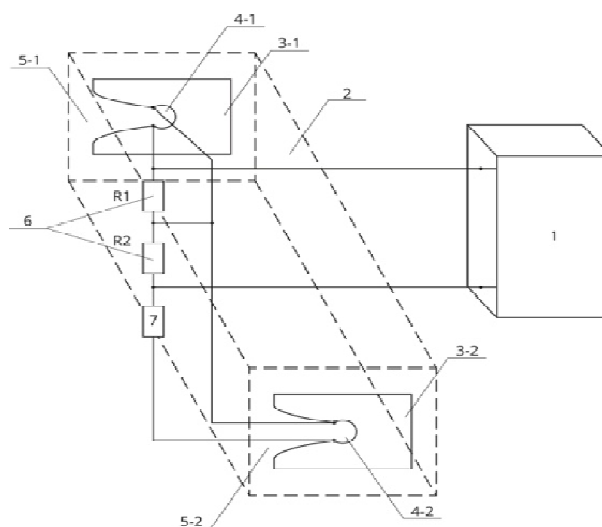

Fig. 4. Antenna for emitting the UWB pulse signal

An informational unipolar pulse signal arrives from the generator 1 onto the divider 6 representing a series connection of two identical non-inductive R1 and R2 resistors allowing it to be halved. The monopulse signal is delivered from the first output of the signal divider R1 directly onto an excitation system 4-1, producing a monopulse electromagnetic field in an aperture 5-1.

Simultaneously, from the other output of a signal divider R2 the inverted monopulse signal is supplied along the delay line 7 onto an excitation system 4-2, creating an inverted monopulse electromagnetic field delayed for a half of duration of a monopulse signal in an antenna

aperture 5-2. In addition, the delay line 7 represents a segment of a homogeneous transmitting line of the specified length.

The electromagnetic fields of two unipolar pulses, the major and inverted ones, are interfered in an equivalent general aperture of antennas, exciting in it an electromagnetic field of a bipolar pulse, which is a broadband pulse signal.

The broadband pulse antenna is capable to emit both an ultrashort unipolar monopulse and a bipolar pulse information signal. The electromagnetic field in the form

of a monopulse is excited by a signal which is described by the expressions:

$$E = E_m \cdot \sin^2 \left[\frac{\pi}{\tau_{im}} \left(t - \frac{r}{v_0} \right) \right] \text{ for } \left| t - \frac{r}{v_0} \right| \leq \tau_{im}, \quad (2)$$

where E_m – a pulse amplitude;

τ_{im} – a pulse duration;

v_0 – speed of distributing the emission.

Besides the electromagnetic field of the antenna has the directive gain (DG) of the antenna emitting a monopulse signal D_{mp} and the antenna emitting a monochromatic signal D_ω with wavelength λ_0 the interrelation between them being defined by the following ratio:

$$D_{mp} = \eta \cdot D_\omega - 0,25 D_\omega, \quad (3)$$

where $D_\omega = \frac{4\pi}{\lambda_0^2} \cdot A_0$;

A_0 – operating antenna aperture area;

$\lambda_0 = v_0 \cdot \tau_{im}$ [10].

The analysis of the ratio (3) shows that the coefficient of efficiency of the antenna which is excited by an ultrashort monopulse comes to 25% comparing with the coefficient of efficiency of the antenna excited by monochromatic signals of the corresponding wavelength. It reduces the range of antenna emission 4 times as much comparing to the emission of monochromatic signals.

Moreover, emission by the antenna of an electromagnetic field in the form of a bipolar impulse can be presented the following ratio for an electric component of an electromagnetic field:

$$E = E_m \cdot \sin^2 \left[\frac{\pi}{\tau_{im}} \left(t - \frac{r}{v_0} \right) \right] \cdot \sin \left[\frac{2\pi}{\tau_{im}} \left(t - \frac{r}{v_0} \right) \right]. \quad (4)$$

So, the DG of the antenna emitting a bipolar pulse signal will be:

$$D_{bp} = 2,37 D_\omega. \quad (5)$$

Thus, the excitation in an antenna aperture of an electromagnetic field in the form of a bipolar pulse increases an antenna DG at 9.5 times as much as compared with a DG of the antenna emitting an unidirectional pulse and 2.37 times as much comparing with a DG of the antenna emitting monochromatic signals. Therefore, the introduced antenna allows increasing significantly the range of radio emission of UBB pulse signals.

The prospects for developing the high-power microwave electronics is associated with creating the high-power relativistic microwave devices which are provided generation of high-power microwave pulses (peak power is units and tens GW) [11]. However, the application of such devices is connected with considerable technical and technological difficulties, especially, when need to produce very short microwave pulses (duration less than 100 ns). In this case for forming high-power UWB microwave pulses there is more simple approach based on the pulse compression technology, namely, the resonant microwave compression method. A central idea of this method is slow storage of electromagnetic energy in the microwave resonator and then its removal from the high factor resonator for shorter duration to a matched load (antenna) [12]. Among advantages of this method it is necessary to note its ease of its realization, the possibility of application the industrial magnetrons as well as the standard elements of waveguide techniques. For understanding a structure of the plant forming the ultrashort microwave pulses let us consider an operation of the microwave module, in which is used the magnetron having the two RF outputs of energy. Fig. 5 shows a block diagram of the microwave module. The magnetron that is used in this experiment has the two RF outputs of energy: active and passive. For tuning and controlling by a frequency of the magnetron we used the tunable short-circuit waveguide as the reactive load of the passive RF output.

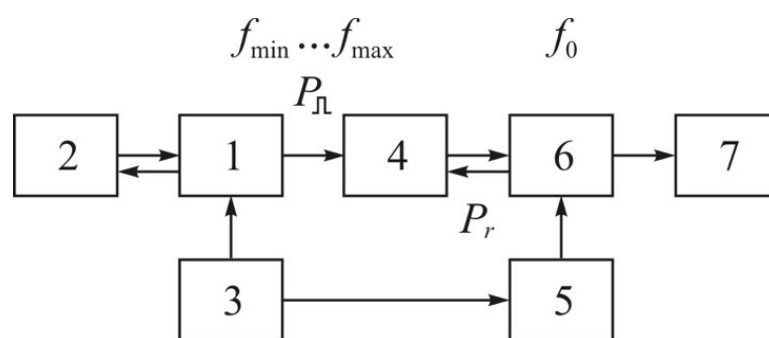

1 – a magnetron with two RF outputs; 2 – a tunable short-circuit waveguide; 3 – a power supply (modulator); 4 – ferrite isolator; 5 – a generator of controlling pulses; 6 – a microwave cavity; 7 – a matched load (TSA antenna)

Fig. 5. Block diagram of the microwave module.

The analysis shows that for increasing an efficiency of compression and formation of the high-power nanosecond microwave pulses necessary to reduce a loss of power P_r . Assuming that $f_{min} < f_0 < f_{max}$ with the help of a short-circuiting piston we adjust an oscillation frequency of the magnetron to a resonant frequency of the microwave cavity and as a result the power P_r , reflected from microwave cavity is decreased. Thus, we have tested the microwave module using the magnetron with the two RF outputs for forming high-power nanosecond microwave pulses at X and K_u bands. Besides it, possibility of application of this approach for creating microwave module at mm range of wavelength is discussed.

Conclusion

The application of the technical solutions proposed for the antenna construction considerably increases a propagation distance of pulse electromagnetic signals. So, as compared with an emission level of a unipolar pulse signal, the propagation distance of the bipolar impulse produced in an antenna aperture increases 9,5 times as much, and as compared with a monochromatic signal – 2,37 times. The simultaneous joint operation with no interference and a single frequency range of both traditional narrow-band communication systems, and communication systems with UWB-SP signals is specified by the fact that the level of an information signal does not exceed a noise level in the working range of frequencies. In addition, decelerating the power and an emission level of electromagnetic fields is guaranteed to provide accomplishing the requirements of electromagnetic compatibility at all development stages and implementing the systems of mobile communication.

References

1. Горбенко І., Замула О., Лик Х. Ч. Comprehensive solution to the problem of electromagnetic compatibility of modern information and communication systems // *Радіотехніка*. 2020. Вип. 202. С. 106–115.
2. Trubchaninova K., Serkov A., Kniyazev V., Yakovenko I. Electromagnetic Compatibility of Mobile Telecommunication Systems // *2020 IEEE Ukrainian Microwave Week (UkrMW)*. 2020. Vol. 1. P. 1041–1044.
3. Ali Grami. *Introduction to Digital Communications*. Academic Press, 2016. 587 p.
4. Zhang, L. The Simulation Study of Multi-User Spread-Spectrum Wireless Communication System // *Journal of Physics: Conference Series* 1815(1):012021. 2021. P. 1–5.
5. United States Federal Communications Commission (FCC) Decision No. FCC 02-48 of 14/02/2002 [Електронний ресурс]. Режим доступа: https://apps.fcc.gov/edocs_public/attachmatch/FCC-02-48A1.pdf. (Дата зверн.: 20.12.2020).
6. Huang Tai-Jung. Analytical Investigation of Channel Capacity of UWB-MIMO Systems // *International Journal of Communications, Network and System Sciences*. 2018. Vol. 11. P. 1–8.
7. Lazurenko B. A., Serkov A. A., Trubchaninova K. A., Horiushkina A. E. Security Improvement Techniques for mobile applications of Industrial Internet of Things. *IJCSNS International Journal of Computer Science and Network Security*. 2020. Vol. 20, No. 5. P. 145–149.
8. Moskalets M., Loshakov V., Abdenour D., Ageyev D., Martynchuk O., Sielivanov K. Methods for Solving EMC Problems by Means of Antenna Technology in Tropospheric Communication // *2019 IEEE International Scientific-Practical Conference Problems*

of Infocommunications, Science and Technology (PIC S&T). 2019. P. 571–574.

9. Спосіб генерації широкосмугового імпульсного сигналу та антена для його реалізації: патент України на винахід № 120554U МПК H01Q 21/06/ В.С. Бреславець; О.А. Серков; М.Ю. Толкачов; Г.І. Чурюмов; І.Г. Перова; заявка № а 2018 03104 подана 26.03.2018; опубл. 26.12.2019, бюл. № 24, 5 с.
10. Serkov O., Breslavets V., Tolkachov M., Churyumov G. The Wideband Pulsed Antenna and its Application // 9th Inter. Conf. on Ultra-wideband and Ultrashort Impulse Signals (UWBUSIS-2018)], September 4 – 7, Odessa Ukraine, 2018. P. 340-343.
11. Trubchaninova K., Serkov A., Mezitis M. Method of wireless transmission of digital information on the basis of ultra-wide signals // Advanced Information Systems. 2019. Vol. 3, Issue 4. P. 33–38. doi: <https://doi.org/10.20998/2522-9052.2019.4.04>.
12. Спосіб прийому цифрових двійкових сигналів в умовах шуму: патент України на корисну модель № 145319 U МПК H04B 1/06 / С. В. Панченко, О.А. Серков, К.А. Трубочанінова, А.Є. Горюшкіна, Б.О. Лазуренко; заявка № u 2020 04847 подана 29.07.2020; опубл. 25.11.20, Бюл. № 22, 6 с.

Чурюмов Г.І., Панченко С.В., Серков О.А., Трубочанінова К.А. Антена для випромінювання та прийому коротко-імпульсних надширокосмугових сигналів

Анотація. У цій статті представлено конструкцію антени з розширюваною щільною для ефективного випромінювання та прийому надширокосмугових сигналів, коротко-імпульсних сигналів. Одним із різновидів надширокосмугових сигналів є коротко-імпульсні сигнали. Вважається, що ці сигнали мають тривалість близько 0,1...10 нс. Вони мають широкую смугу пропускання, значне проникнення і скритність. Їх використання дозволяє отримати високі швидкості передачі даних і є дуже перспективним для майбутнього розвитку сучасних ультра-широкосмугових систем (UWS). З іншого боку, практичне застосування сигналів SP-UWB викликає певні труднощі, пов'язані з їх випромінюванням (або вибором типу антени) і подальшими спотвореннями, викликаними нерівномірним ослабленням сигналу по частоті під час його поширення. Таким чином, ефективність використання сигналів SP-UWB безпосередньо залежить від характеристик антен, які здійснюють їх випромінювання та прийом. В роботі запропонована конструкція антени, яка дозволяє створювати інтерференційне електромагнітне поле біполярного імпульсу в еквівалентній загальній апертурі антени. Проведено кількісну та якісну оцінку ефективності запропонованої конструкції антени.

Показано, що застосування даної антени дозволяє збільшити дальність поширення імпульсних UWB сигналів. Так, порівняно з рівнем випромінювання уніполярного імпульсного сигналу дальність поширення біполярного імпульсу, створеного в отворі антени, збільшується в 9,5 рази, а порівняно з монохроматичним сигналом – у 2,37 рази. Таким чином, введена антена дозволяє істотно збільшити дальність радіовипромінювання імпульсних надширокосмугових сигналів. Одночасна сумісна робота без перешкод і в одному частотному діапазоні як традиційних вузькосмугових систем зв'язку, так і систем зв'язку з UWB-SP сигналами обумовлюється тим, що рівень інформаційного сигналу не перевищує рівня шуму в робочому стані. Діапазон частот.

Ключові слова: передавання даних, електромагнітна сумісність, часова позиційно-імпульсна модуляція, надширокосмуговий сигнал, широкосмугова імпульсна антена, бездротова система.

Надійшла 17.05.2023 р.

Churyumov Gennadiy, Doctor of Sciences (Physical and Mathematical), Full Professor, Professor of Physical Fundamentals of Electronic Engineering Department, Kharkiv National University of Radio Electronics, Kharkiv, Ukraine.

E-mail: gennadiy.churyumov@nure.ua

<https://orcid.org/0000-0002-4826-510X>.

Panchenko Sergii, Doctor of sciences (engineering), Full Professor, Rector of Ukrainian State University of Railway Transport, Kharkiv, Ukraine.

E-mail: panchenko074@ukr.net

<https://orcid.org/0000-0002-7626-9933>.

Serkov Oleksandr, Doctor of sciences (engineering), Full Professor, Professor of Information Systems Department, National Technical University «Kharkiv Polytechnic Institute», Kharkiv, Ukraine.

E-mail: aleksandr.serkov@hotmail.com

<https://orcid.org/0000-0002-6446-5523>.

Trubchaninova Karyna, Doctor of sciences (engineering), Full Professor, Professor of Transport Communication Department, Ukrainian State University of Railway Transport, Kharkiv, Ukraine.

E-mail: tka2@ukr.net

<https://orcid.org/0000-0003-2078-2647>.

Чурюмов Геннадій Іванович, доктор фізико-математичних наук, професор, професор кафедри фізичних основ електронної техніки, Харківський національний університет радіоелектроніки, Харків, Україна.

E-mail: gennadiy.churyumov@nure.ua

<https://orcid.org/0000-0002-4826-510X>.

Панченко Сергій Володимирович, доктор технічних наук, професор, ректор Українського державного університету залізничного транспорту, Харків, Україна.

Е-mail: panchenko074@ukr.net

<https://orcid.org/0000-0002-7626-9933>.

Серков Олександр Анатолійович, доктор технічних наук, професор, професор кафедри систем інформації, Національний технічний університет «Харківський політехнічний інститут», Харків, Україна.

Е-mail: aleksandr.serkov@hotmail.com

<https://orcid.org/0000-0002-6446-5523>.

Трубчанінова Карина Артурівна, доктор технічних наук, професор, професор кафедри транспортного зв'язку, Український державний університет залізничного транспорту, Харків, Україна.

Е-mail: tka2@ukr.net

<https://orcid.org/0000-0003-2078-2647>.